

# Magnetic Contactor/ Switches





## Functionalities and characteristics of Magnetic Contactor

- Configuration**

Composite magnetic switch (abbreviated as MS) is comprised of a contactor for switching on and off current and a thermal overload relay for protecting the load.

- Functions**

- Switching the control system for electric power transmission and distribution.
- Operation of the start and stop of motors.
- Electric power control for all kinds of industrial machinery, machine tools, injection molding machines.

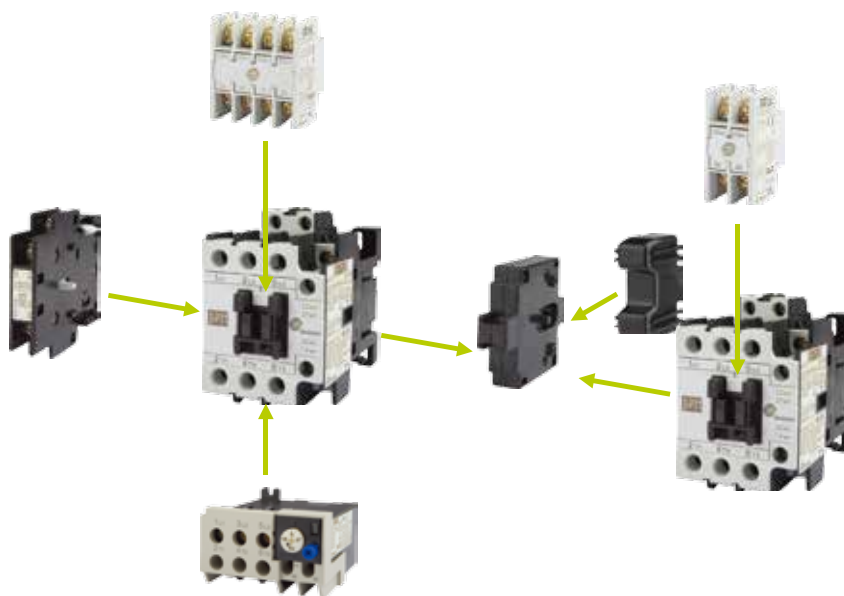

- Feature**

- Products comply with multiple international standards.  
Compliant standards: JIS, JEM, IEC, EN, VDE  
Certificate: UL, UR, CSA, TUV, CE
- Auxiliary Contact Block designed for installing on the front and on the side can satisfy the spatial requirements of different operating environments.



Charact-eristics

SP

Series

MS

Series

Other

Series

Coil

TH

Series

SD

Series

Selec-tion

Others

c. Increase the reliability of auxiliary contacts (S-P60T and lower).

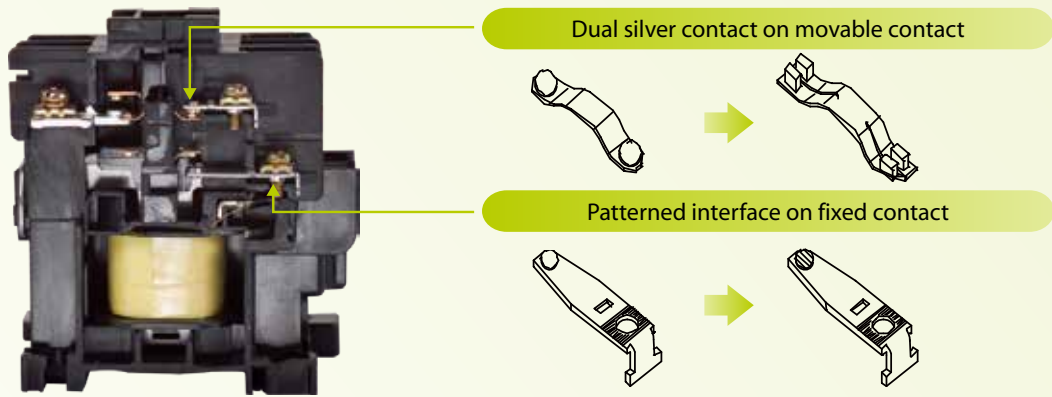

Notes:  
Apply the above auxiliary terminal design can increase the reliability of the contacts and minimize the contact resistance variation.

• Descriptions of product characteristics S-P300、S-P400

Category	Product features
Usability	<ul style="list-style-type: none"> <li>• Energy saving design with low power consumption for operating coils and operating VA capacity.</li> <li>• Operating coils apply common AC/DC power, AC or DC operation, DC holding, absolutely free of electromagnetic noise.</li> <li>• Wide range of operating voltage 100-240V, 265-450V, 440-575V, ease of customer use.</li> </ul>
Internationalization	<ul style="list-style-type: none"> <li>• Compliant with IEC, CE, UL, TUV worldwide standards.</li> </ul>
Safety	<ul style="list-style-type: none"> <li>• Spaced safety partition design: prevent short-circuit accidents caused by falling foreign objects.</li> <li>• Safety trip mechanism design: when main contact melts down, auxiliary NC contact will break apart and open.</li> <li>• Trip indication safety mechanism design: prevent external forces or human faulty activation which could lead to false function that bring about danger.</li> <li>• Highly voltage drop withstand coil design (prevent the motor from starting at insufficient voltage [<math>&lt;65\%U_s</math> is not allowed to activate]).</li> </ul>
Others	<ul style="list-style-type: none"> <li>• Contact material does not contain cadmium, which complies with RoHs requirements</li> </ul>

Characteristics

SP  
Series

MS  
Series

Other  
Series

Coil

TH  
Series

SD  
Series

Selection

Others

## Description of thermal overload relay

- **Automatic temperature compensation design**

Bi-metal design can adjust and compensate automatically for ambient temperature changes, which increase the reliability of the product.

- **Single unit installation base can be added for independent use**

TH-P12, TH-P18 can be installed to single unit installation base, which can be used independently on the track or be fixed on the installation plate.

- **Safety terminal cover design for high safety level**

Terminal cover, is easy to install and complies with IEC degree of protection of IP 20.

- **Auxiliary terminal of thermal overload relay is 1NO 1NC**

The auxiliary contact are designed independently, which can be used for the control of two different power sources and are convenient for wiring.

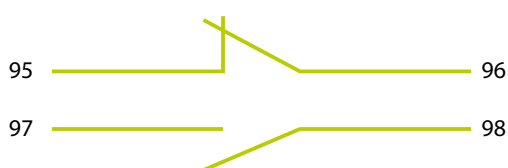

- **Thermal overload relay reset/trip indicator can be seen easily and clear**

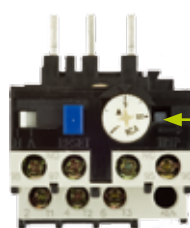

(Reset state)  
White rod will appear in the indicator window.



(Trip) White rod shifted and unable to be seen directly.

- **Switching of thermal overload relay between manual/automatic reset is easy**

(customers can switch by themselves according to their needs)



**TH-P12**

**Manual → Automatic reset switching method**

Press reset button down and hold it; in the meantime, pull switch plate to the right to position “A” to lock reset rod and keep it in pressed down state, which then becomes the automatic reset state.

**Automatic → Manual reset switching method**

Pull switch plate to the left to position “H” to have reset rod recoiled back upward and finish.

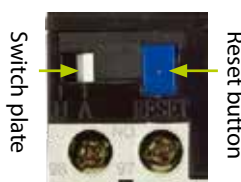

**TH-P20~TH-P600**

**Manual → Automatic reset switching method**

Use cross screwdriver and align it with the cross hole on the top of reset button, engage and drive the button rotating it 90° counterclockwise to have the arrow points from “H” to “A” and keep reset button in pressed down state.

**Automatic → Manual reset switching method**

Use cross screwdriver and align it with the cross hole on the top of reset rod, engage and drive the rod rotating it 90° clockwise to have the arrow points from “A” to “H” and the reset rod recoiled back to its original position.

Characteristics

SP

Series

MS

Series

Other

Series

Coil

TH

Series

SD

Series

Selection

Others

MS | S-P Series

Type designation



S-P21



S-2×P30T

MS | MS-P Series

Type designation



MSO-P11



MSO-2×P11



MS-P11PB



MS-2×P11

S	-	2×	P	35T	220V
1		2	3	4	5

1	<b>Model</b>
	S : AC Magnetic contactor
2	<b>Non-reversing/reversing</b>
	Blank   Non-reversing
	2×   Reversing
3	<b>Series</b>
	P   P Series
4	<b>Rated capacity</b>
	11、12、15、16、21、25、30T、35T、40T、50T、60T、80T、100T、125T、150T、200T、220T、300T、400T、600
5	<b>Control circuit voltage</b>
	EX. 110V、220V、380V、440V (Refer to P34)

MS	-	2×	P	35T	PB	380V/	220V	28A	E
1		2	3	4	5	6	7	8	9

1	<b>Model</b>
	MSO   AC Magnetic contactor without enclosure
	MS   AC Magnetic contactor with enclosure
2	<b>Non-reversing/reversing</b>
	Blank   Non-reversing
	2×   Reversing
3	<b>Series</b>
	P   P Series
4	<b>Rated capacity</b>
	11、12、15、16、21、25、30T、35T、40T、50T、60T、80T、100T、125T、150T、200T、220T、300T、400T、600
5	<b>Push button</b>
	Blank   Non- Push button type
	PB   With Push button type (MSO model is without PB)
6	<b>Main circuit voltage</b>
	EX : 110V、220V、380V、440V (When main circuit voltage and control circuit voltage are the same, it will be blank.)
7	<b>Control circuit voltage</b>
	EX : 110V、220V、380V、440V... (Refer to P34)
8	<b>TH heater rated capacity</b>
	EX : 3.3A、6.5A、9A、11A、15A...350A...
9	<b>TH Type</b>
	Blank   Compressor Type (Two-element)
	E   Three-element type
	PP   Phase failure protection type

# Magnetic Contactor / Switch ◆ AC control



Model		06	09	11	12		
Type	Magnetic Contactor	Nonreversing	S-P06	S-P09	S-P11	S-P12	
		Reversing	S-2×P06	S-2×P09	S-2×P11	S-2×P12	
	Magnetic Switch	without enclosure	Nonreversing	MSO-P06	MSO-P09	MSO-P11	MSO-P12
			Reversing	—	—	MSO-2×P11	MSO-2×P12
		with enclosure	Nonreversing	—	—	MS-P11	MS-P12
			Reversing	—	—	MS-2×P11	MS-2×P12
		with enclosure (push button)	Nonreversing	—	—	MS-P11PB	MS-P12PB
Thermal overload relay	Standard	—	—	TH-P12 E	TH-P12 E		
	With phase failure protection	TH-P09PP	TH-P09PP	TH-P12PP	TH-P12PP		
Rated Capacity	IEC 60947-4-1 EN 60947-4-1 DIN VDE 0660  AC 3 (kW/HP/A)	3 φ	240V	1.5/ 2/ 6	2.2/ 3/ 9	3.5/ 4.5/ 13	3.5/ 4.5/ 13
			380V	3/ 4/ 6	4/ 5.5/ 9	5.5/ 7.5/ 12	5.5/ 7.5/ 12
			440V	3/ 4/ 6	4/ 5.5/ 9	5.5/ 7.5/ 12	5.5/ 7.5/ 12
			550V	3/ 4/ 6	4/ 5.5/ 9	5.5/ 7.5/ 9	5.5/ 7.5/ 9
			660V	—	—	5.5/ 7.5/ 7	5.5/ 7.5/ 7
		Operation current (I <sub>th</sub> ) AC1 (A)	20	20	20	20	
	Rated impulse voltage (U <sub>i</sub> ) (V)	AC660	AC660	AC660	AC660		
	UL 508 CSA-C22.2  AC3 (HP/A)	1 φ	100~120V	0.25/ 5.8	0.5/ 9.8	0.5/ 9.8	0.5/ 9.8
			200~240V	1/ 8	1.5/ 10	2/ 10	2/ 12
		3 φ	200~240V	2/ 6.8	3/ 9.6	3/ 9.6	3/ 9.6
			380~480V	3/ 4.8	5/ 7.6	7.5/ 11	7.5/ 11
			550~600V	3/ 3.9	5/ 6.1	10/ 11	10/ 11
		Operation current (I <sub>th</sub> ) AC1 (A)	20	20	24	24	
	Rated impulse voltage (U <sub>i</sub> ) (V)	AC660	AC660	AC600	AC600		
NEMA		00	00	0	0		
Auxiliary Contact	IEC 60947-5-1 EN 60947-5-1 GB14048.4  AC 15	Contact	Standard	1NO	1NO	1NO	1NO 1NC
			Special	1NC	1NC	1NC	2NC or 2NO
			220V	3.3	3.3	1.6	1.6
			380V	1.9	1.9	0.95	0.95
	Operation current (I <sub>th</sub> ) AC1 (A)	10	10	16	16		
Contact class (UL)	A600	A600	A600, P600, Q300	A600, P600, Q300			
Electrical Life	AC3 (10 thousand)	120	120	120	120		
Mechanical Life	(10 thousand)	600	600	600	600		
Magnetic Contactor	Weight (kg)	0.15	0.15	0.33	0.35		
	Installation Dimensions (L×W×H) (mm)	58×46×51	58×46×51	81×43×83.5	81×53×83.5		
	Dimensions (mm)						
Mechanical Interlock		—	—	MPU-11	MPU-21		

MAGNETIC SWITCH

Charact-eristics

SP

Series

MS

Series

Other

Series

Coil

TH

Series

SD

Series

Selec-tion

Others

MS

# Magnetic Contactor / Switch ◆ AC control

MAGNETIC SWITCH

Characteristics

SP Series

MS Series

Other Series

Coil

TH Series

SD Series

Selection

Others

MS



Model		15	16	21 (A)	25		
Type	Magnetic Contactor	Nonreversing	S-P15	S-P16	S-P21 (A)	S-P25	
		Reversing	S-2×P15	S-2×P16	S-2×P21 (A)	S-2×P25	
	Magnetic Switch	without enclosure	Nonreversing	MSO-P15	MSO-P16	MSO-P21 (A)	MSO-P25
			Reversing	MSO-2×P15	MSO-2×P16	MSO-2×P21 (A)	MSO-2×P25
		with enclosure	Nonreversing	MS-P15	MS-P16	MS-P21 (A)	MS-P25
			Reversing	MS-2×P15	MS-2×P16	MS-2×P21 (A)	MS-2×P25
		with enclosure (push button)	Nonreversing	MS-P15PB	MS-P16PB	MS-P21PB (A)	MS-P25PB
		Thermal overload relay	Standard	TH-P12 E	TH-P20 E	TH-P20 E	TH-P20 E(TA)
	With phase failure protection		TH-P12PP	TH-P20PP	TH-P20PP	TH-P20(TA)PP	
	Rated Capacity	IEC 60947-4-1 EN 60947-4-1 DIN VDE 0660 AC 3 (kW/HP/A)	3 Ø	240V	4.5/ 6/ 18	4.5/ 6/ 18	5.5/ 7.5/ 24
380V				7.5/ 10/ 16	7.5/ 10/ 18	11/ 15/ 21	12/ 16/ 23
440V				7.5/ 10/ 16	7.5/ 10/ 16	11/ 15/ 21	12/ 16/ 23
550V				7.5/ 10/ 13	7.5/ 10/ 13	11/ 15/ 17	12/ 16/ 20
660V				7.5/ 10/ 9	7.5/ 10/ 9	11/ 15/ 14	12/ 16/ 16
Operation current (Ith) AC1 (A)		25	30	32	32		
Rated impulse voltage (Ui) (V)		AC660	AC660	AC660	AC660		
UL 508 CSA-C22.2 AC3 (HP/A)		1 Ø	100~120V	—	1/ 16	2/ 24	2/ 24
			200~240V	—	3/ 17	3/ 17	3/ 17
		3 Ø	200~240V	—	5/ 15.2	7.5/ 22	10/ 28
			380~480V	—	10/ 14	15/ 21	15/ 21
			550~600V	—	10/ 11	15/ 17	15/ 17
		Operation current (Ith) AC1 (A)		—	30	35	40
		Rated impulse voltage (Ui) (V)		—	AC600	AC600	AC600
NEMA		0	0	1	1		
Auxiliary Contact	IEC 60947-5-1 EN 60947-5-1 GB14048.4 AC 15	Contact	Standard	1NO	1NO 1NC	1NO 1NC (2NO 2NC)	1NO 1NC
			Special	1NC	—	—	—
		220V	1.6	1.6	1.6	1.6	
			380V	0.95	0.95	0.95	0.95
	Operation current (Ith) AC1 (A)		16	16	16	16	
	Contact class (UL)		—	A600, Q300	A600, Q300	A600, Q300	
Electrical Life AC3 (10 thousand)		120	120	120	120		
Mechanical Life (10 thousand)		600	600	600	600		
Magnetic Contactor	Weight (kg)		0.33	0.37	0.38	0.38	
	Installation Dimensions (L×W×H) (mm)		81×43×83.5	81×53.5×83.5	81×53.5×83.5	81×53.5×83.5	
	Dimensions (mm)						
Mechanical Interlock		MPU-11	MPU-21	MPU-21	MPU-21		



30T	35T	40T	50T	60T
S-P30T	S-P35T	S-P40T	S-P50T	S-P60T
S-2×P30T	S-2×P35T	S-2×P40T	S-2×P50T	S-2×P60T
MSO-P30T	MSO-P35T	MSO-P40T	MSO-P50T	MSO-P60T
MSO-2×P30T	MSO-2×P35T	MSO-2×P40T	MSO-2×P50T	MSO-2×P60T
MS-P30T	MS-P35T	MS-P40T	MS-P50T	MS-P60T
MS-2×P30T	MS-2×P35T	MS-2×P40T	MS-2×P50T	MS-2×P60T
MS-P30TPB	MS-P35TPB	MS-P40TPB	MS-P50TPB	MS-P60TPB
TH-P20 E(TA)	TH-P20 E(TA)	TH-P20 E(TA)	TH-P60 E	TH-P60 E(TA)
TH-P20(TA)PP	TH-P20(TA)PP	TH-P20(TA)PP	TH-P60PP	TH-P60(TA)PP
7.5/ 10/ 30	9/ 12.5/ 35	11/ 15/ 44	15/ 20/ 58	19/ 25/ 65
15/ 20/ 28	18.5/ 25/ 30	22/ 30/ 40	30/ 40/ 52	37/ 50/ 65
15/ 20/ 27	18.5/ 25/ 27	22/ 30/ 40	30/ 40/ 52	37/ 50/ 65
15/ 20/ 22	18.5/ 25/ 22	22/ 30/ 32	30/ 40/ 41	37/ 50/ 52
15/ 20/ 18	18.5/ 25/ 18	22/ 30/ 26	30/ 40/ 34	37/ 50/ 43
50	50	50	80	90
AC660	AC660	AC660	AC660	AC660
—	2/ 24	3/ 34	5/ 56	5/ 56
—	5/ 28	7.5/ 40	10/ 50	10/ 50
—	10/ 28	15/ 42	20/ 54	20/ 54
—	20/ 27	20/ 27	30/ 40	40/ 52
—	30/ 32	30/ 32	40/ 41	50/ 52
—	50	50	80	90
—	AC600	AC600	AC600	AC600
1	2	2	2	2
2NO 2NC	2NO 2NC	2NO 2NC	2NO 2NC	2NO 2NC
—	—	—	—	—
1.6	1.6	1.6	1.6	1.6
0.95	0.95	0.95	0.95	0.95
16	16	16	16	16
—	A600, Q300	A600, Q300	A600, Q300	A600, Q300
120	120	120	120	120
600	600	600	600	600
0.38	0.55	0.55	1.05	1.05
81×53.5×83.5	95×73×93	95×73×93	115×87.9×107	115×87.9×107

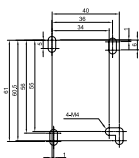

MPU-11

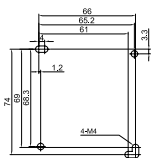

MPU-11

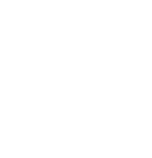

MPU-11

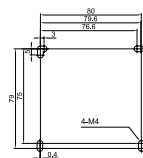

MPU-11



MPU-11

Characteristics

SP

Series

MS

Series

Other

Series

Coil

TH

Series

SD

Series

Selection

Others

# Magnetic Contactor / Switch ◆ AC control

MAGNETIC SWITCH



Model		80T	100T	125T	150T		
Type	Magnetic Contactor	Nonreversing	S-P80T	S-P100T	S-P125T	S-P150T	
		Reversing	S-2×P80T	S-2×P100T	S-2×P125T	S-2×P150T	
	Magnetic Switch	without enclosure	Nonreversing	MSO-P80T	MSO-P100T	MSO-P125T	MSO-P150T
			Reversing	MSO-2×P80T	MSO-2×P100T	MSO-2×P125T	MSO-2×P150T
		with enclosure	Nonreversing	MS-P80T	MS-P100T	MS-P125T	MS-P150T
			Reversing	MS-2×P80T	MS-2×P100T	MS-2×P125T	MS-2×P150T
with enclosure (push button)	Nonreversing	—	—	—	—		
Thermal overload relay	Standard	TH-P60 E(TA)	TH-P120 E(TA)	TH-P120 E(TA)	TH-P120 E(TA)		
	With phase failure protection	TH-P60(TA)PP	TH-P120(TA)PP	TH-P120(TA)PP	TH-P120(TA)PP		
Rated Capacity	IEC 60947-4-1 EN 60947-4-1 DIN VDE 0660	3 φ	240V	22/ 30/ 80	30/ 40/ 105	37/ 50/ 135	45/ 60/ 165
			380V	45/ 60/ 80	60/ 80/ 105	75/ 100/ 130	90/ 125/ 160
			440V	45/ 60/ 75	60/ 80/ 105	75/ 100/ 130	90/ 125/ 160
			550V	45/ 60/ 60	60/ 80/ 85	75/ 100/ 105	90/ 125/ 130
			660V	45/ 60/ 50	60/ 80/ 70	75/ 100/ 90	90/ 125/ 110
	AC 3 (kW/HP/A)	Operation current (Ith) AC1 (A)	100	135	170	200	
		Rated impulse voltage (Ui) (V)	AC660	AC660	AC660	AC660	
	UL 508 CSA-C22.2	1 φ	100~120V	7.5/ 80	—	—	—
			200~240V	15/ 68	—	—	—
		3 φ	200~240V	25/ 68	30/ 80	50/ 130	60/ 154
			380~480V	50/ 65	60/ 77	100/ 124	125/ 156
			550~600V	60/ 62	60/ 62	100/ 99	125/ 125
AC3 (HP/A)	Operation current (Ith) AC1 (A)	90	100	170	200		
	Rated impulse voltage (Ui) (V)	AC600	AC600	AC600	AC600		
NEMA		3	3	3	3		
Auxiliary Contact	IEC 60947-5-1 EN 60947-5-1 GB14048.4	Contact	Standard	2NO 2NC	2NO 2NC	2NO 2NC	2NO 2NC
			Special	—	—	—	—
			220V	1.6	1.6	3.3	3.3
			380V	0.95	0.95	1.6	1.6
	AC 15	Operation current (Ith) AC1 (A)	16	16	16	16	
Contact class (UL)	A600, Q300	A600, Q300	A600, Q300	A600, Q300			
Electrical Life AC3 (10 thousand)		120	120	120	120		
Mechanical Life (10 thousand)		600	600	600	600		
Magnetic Contactor	Weight (kg)	1.5	2.35	2.7	2.7		
	Installation Dimensions (L×W×H) (mm)	142×93×116	116×120×128	152.5×106×140	152.5×106×140		
	Dimensions (mm)						
Mechanical Interlock		MPU-50	Install by manufacturer	MPU-125	MPU-125		

MS



200T	220T	300T	400T	600C
S-P200T	S-P220T	S-P300T	S-P400T	M-600C
S-2×P200T	S-2×P220T	S-2×P300T	S-2×P400T	RC-600C
MSO-P200T	MSO-P220T	MSO-P300T	MSO-P400T	—
MSO-2×P200T	MSO-2×P220T	MSO-2×P300T	MSO-2×P400T	—
MS-P200T	MS-P220T	—	—	—
MS-2×P200T	MS-2×P220T	—	—	—
—	—	—	—	—
TH-P220T E	TH-P220T E	TH-P400T E	TH-P400T E	TH-P600 E
TH-P220TPP	TH-P220TPP	TH-P400TPP	TH-P400TPP	TH-P600PP
55/ 75/ 200	65/ 85/ 220	90/ 125/ 300	110/ 150/ 400	160/ 220/ 620
110/ 150/ 190	120/ 160/ 220	160/ 220/ 300	220/ 300/ 400	315/ 420/ 620
110/ 150/ 190	120/ 160/ 190	185/ 250/ 300	250/ 340/ 400	315/ 420/ 600
110/ 150/ 150	132/ 180/ 180	185/ 250/ 263	250/ 340/ 360	315/ 420/ 500
110/ 150/ 125	132/ 180/ 150	200/ 300/ 220	280/ 380/ 280	—
240	260	350	450	660
AC660	AC660	AC1000	AC1000	AC660
—	—	—	—	—
—	—	—	—	—
75/ 192	75/ 192	100/ 248	125/ 312	—
150/ 180	150/ 180	200/ 240	250/ 302	—
150/ 144	150/ 144	200/ 192	300/ 289	—
240	260	350	450	—
AC600	AC600	AC1000	AC1000	—
4	4	5	5	6
2NO 2NC	2NO 2NC	2NO 2NC	2NO 2NC	2NO 2NC
—	—	—	—	—
3.3	3.3	3.3	3.3	1.6
1.6	1.6	1.6	1.6	0.95
16	16	10	10	16
A600, Q300	A600, Q300	A600, Q300	A600, Q300	A600, Q300
120	120	120	120	60
600	600	600	600	600
4.35	4.35	9.75	9.75	28

Characteristics

SP Series

MS Series

Other Series

Coil

TH Series

SD Series

Selection

Others

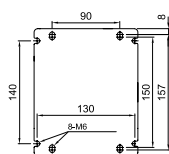

MPU-125

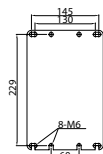

MPU-125

MPU-125

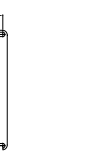

MPU-125

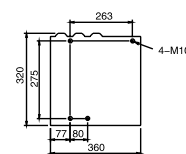

—

Other | SD Series | DC control type

Type designation



SD	-	2x	P	21	220V
①		②	③	④	⑤

①	Model	SD	DC Contactor
②	Non-reversing/reversing	Blank	Non-reversing
		2x	Reversing
③	Series	P	P Series
④	Rated capacity	11、16、21	
⑤	Control circuit voltage	EX : 12V、24V、48V...110V、220V... (Refer to P33)	

Other | MDO Series | DC control type

Type designation

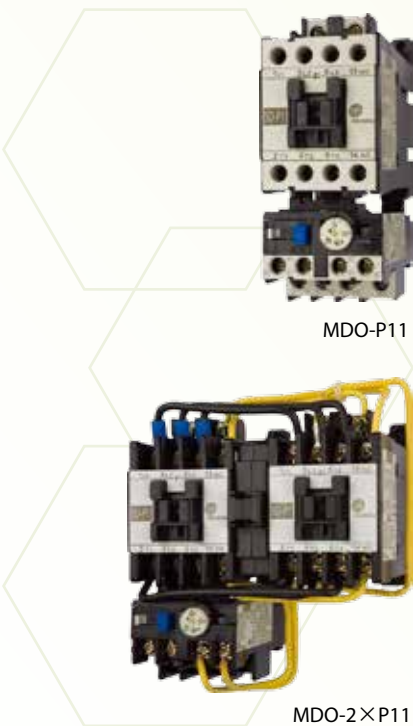

MDO	-	2x	P	21	380V /	220V	28A	E
①		②	③	④	⑤	⑥	⑦	⑧

①	Model	MDO	DC Magnetic Switch without enclosure
②	Non-reversing/reversing	Blank	Non-reversing
		2x	Reversing
③	Series	P	P Series
④	Rated capacity	11、16、21	
⑤	Main circuit voltage	EX : 110V、220V、380V、440V... (When main circuit voltage and control circuit voltage are the same, it will be blank.)	
⑥	Control circuit voltage	EX : 12V、24V、48V...110V、220V...	
⑦	TH heater rated capacity	EX : 3.3A、6.5A、9A、11A...21A...	
⑧	TH Type	Blank	Compressor Type (Two-element)
		E	Three-element type
		PP	Phase failure protection

Charact-eristics

SP

Series

MS

Series

Other

Series

Coil

TH

Series



SD

Series

Selec-tion

Others

# Magnetic Contactor / Switch ◆ DC control

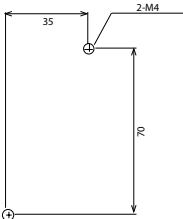
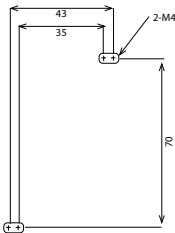
							
	Magnetic Contactor	Nonreversing		SD-P11	SD-P16	SD-P21	
		Reversing		SD-2×P11	SD-2×P16	SD-2×P21	
Type	Magnetic Switch	without enclosure	Nonreversing	MDO-P11	MDO-P16	MDO-P21	
			Reversing	MDO-2×P11	MDO-2×P16	MDO-2×P21	
		with enclosure	Nonreversing	—	—	—	
			Reversing	—	—	—	
		with enclosure (push button)	Nonreversing	—	—	—	
			Thermal overload relay	Standard	TH-P12	TH-P20	TH-P20
		With phase failure protection	TH-P12PP	TH-P20PP	TH-P20PP		
Rated Capacity	IEC 60947-4-1 EN 60947-4-1 DIN VDE 0660	3 ∅	240V	3.5/ 4.5/ 13	4.5/ 6/ 18	5.5/ 7.5/ 24	
			380/440V	5.5/ 7.5/ 12	7.5/ 10/ 18	11/ 15/ 21	
			550V	5.5/ 7.5/ 9	7.5/ 10/ 13	11/ 15/ 17	
			660V	5.5/ 7.5/ 7	7.5/ 10/ 9	11/ 15/ 14	
	AC 3 (kW/HP/A)	Operation current (Ith) AC1 (A)		20	30	32	
	UL 508 CSA-C22.2	1 ∅	110~120V	0.5/ 9.8	1/ 16	2/ 24	
			220~240V	2/ 12	3/ 17	3/ 17	
		3 ∅	220~240V	3/ 9.6	5/ 15.2	7.5/ 22	
			440~480V	7.5/ 11	10/ 14	15/ 21	
	AC3 (HP/A)	550~600V		10/ 11	10/ 11	15/ 17	
			Operation current (Ith) AC1 (A)		24	30	35
	NEMA				0	0	1
Auxiliary contact				1NO or 1NC	1NO 1NC	1NO 1NC	
Control coil voltage DC (V)				12/ 24/ 48/ 72/ 110/ 125/ 220			
Electrical Life	AC3 (10 thousand)			120	120	120	
Mechanical Life	(10 thousand)			600	600	600	
Magnetic Contactor	Weight (kg)			0.33	0.37	0.38	
	Installation Dimensions (L×W×H) (mm)			81×43×83.5	81×53.5×83.5	81×53.5×83.5	
	Dimensions (mm)						
Mechanical Interlock				MPU-11	MPU-11	MPU-11	

Charact-eristics

SP

Series

MS

Series

Other

Series

Coil

TH

Series

SD

Series

Selec-tion

Others

Type designation

S	-	P	35	SC	220V
①		②	③	④	⑤

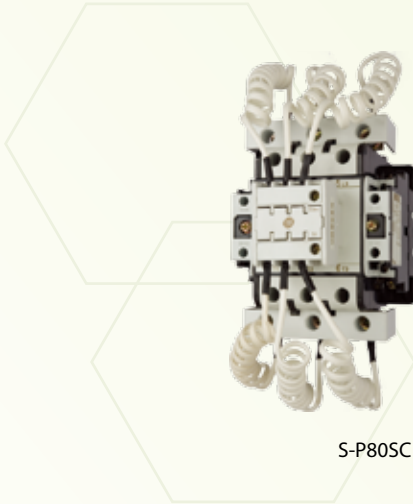

S-P80SC

①	<b>Model</b>	
	S	Electromagnetic contactor
②	<b>Series</b>	
	P	P Series (Non-reversing)
③	<b>Rated capacity</b>	
		11、16、21、35、60、80
④	<b>Purposes</b>	
	SC	Applied to switching capacitor type.
⑤	<b>Control circuit voltage</b>	
		EX : 110V、220V、380V、440V

● Feature:

a : applicable to rated voltage AC600V and below, with frequency at 50Hz/60Hz, and applied as a contactor for connecting and disconnecting low-voltage capacitors in parallel.

b : contactor is equipped with current limiting resistor, which can suppress surge current output from capacitors when they are initially connected, which could effectively reduce the impact of surge current to the capacitors and increase the life and reliability of capacitors.

Charact-eristics

SP

Series

MS

Series

Other

Series

Coil

TH

Series

SD

Series

Selec-tion

Others

# Capacitor Contactors

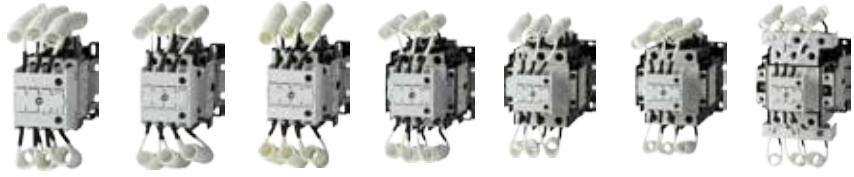

Type		SC-P12	SC-P16	SC-P20	SC-P25	SC-P33	SC-P45	SC-P60		
Rated impulse voltage (Ui)		(V)	690	690	690	690	690	690		
Rated Capacity	IEC 60947-4-1 EN 60947-4-1 DIN VDE 0660  AC 3 (kW/HP/A)	AC-6b 3 φ (kVar/A)	200~240V	6.7/ 18	8.5/ 22	10/ 26	15/ 39	20/ 48	25/ 66	35/ 92
			400~440V	12.5/ 16	16.7/ 22	20/ 26	25/ 33	33.3/ 44	45/ 59	60/ 86
			660~690V	18/ 15	24/ 20	30/ 25	36/ 30	48/ 40	58/ 49	75/ 63
	Operation current (Ith) AC1 (A)			20	30	40	50	80	90	100
Auxiliary Contact			2NO or 1NO 1NC	2NO 1NC	2NO 1NC	3NO 2NC	3NO 2NC	3NO 2NC	3NO 2NC	
Auxiliary Contact	IEC 60947-5-1 EN 60947-5-1	AC12 (A)	100~120V	6	6	6	6	6	6	
			200~220V	5	5	5	5	5	5	
			380~440V	3	3	3	3	3	3	
			550~600V	3	3	3	3	3	3	
	Operation current (Ith) (A)			16	16	16	16	16	16	
Mechanical Life / Electrical Life (AC-6b)		(10 thousand)	500 / 30	500 / 30	500 / 30	500 / 30	500 / 30	500 / 30		
On/ Off Frequency		(time/ hour)	240	240	240	240	240	240		
Weight		(kg)	0.43	0.48	0.48	0.64	1.15	1.15	1.6	
Installation Dimensions (L×W×H)		(mm)	125×43×112	130×53.5×112	130×53.5×112	143×60×121	164×88×135.5	164×88×135.5	180×100×144	
Magnetic Contactor	Dimensions									

Charact-eristics

SP

Series

MS

Series

Other

Series

Coil

TH

Series

SD

Series

Selec-tion

Others

Type designation

SF	-	20	C	2	M
①		②	③	④	⑤

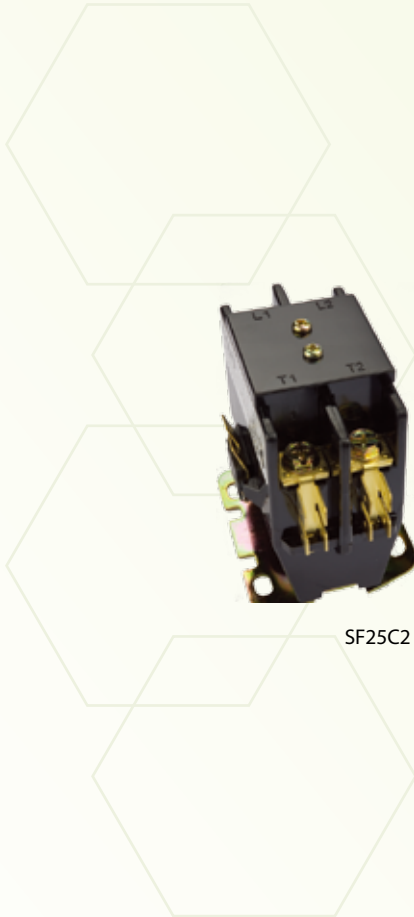

①	Model	
	SF	Definite purposes

②	Rated capacity	
	20, 25, 30, 35, 40	

③	Type	
	C	close type

④	Contact structure	
	1	1 Pole
	2	2 Pole
	3	1 Pole + conductor contact

⑤	Code of Coil voltage						
	Frequency	H	A	L	M	B	F
	50Hz	24V	110~120V	200V	220V	208~240V	277V
	60Hz	24V	110~120V	200V	220V	208~240V	277V

● Features:

- All contacts are AMP250 quick contacts , which saves wiring
- Compact size saving panel space.
- Standard dimensions of the installation holes, compliant with the installation dimensions of the product of the same grade made by other brands.
- Comply with Air-conditioning and Refrigeration Institute, USA ARI 780/790 standards.
- Certified by cUL and compliant with the US UL508 standards.
- Certified by CSA, compliant with Canadian C.S.A. C22.2 No.14 standards.
- Comply with IEC 60947-4-1 standards, CE marking.
- Operating voltage of coil: 85%~105% rated voltage

Charact-eristics

SP

Series

MS

Series

Other

Series

Coil

TH

Series

SD

Series

Selec-tion

Others

## Definite Purpose Magnetic Contactor | SF Series

Type		20	25	30	35	40
		 C1	 C2	 C3		
Type	1 Pole	SF20C1	SF25C1	SF30C1	SF35C1	SF40C1
	2 Pole	SF20C2	SF25C2	SF30C2	SF35C2	SF40C2
	1Pole w/shunt	SF20C3	SF25C3	SF30C3	SF35C3	SF40C3
Start Current(A) (Per Pole)	AC 240V / AC 277V	120	150	180	180	180
	AC 480V	100	125	150	150	150
	AC 600V	80	100	120	120	120
Start Current(A) (Single Phase) (2 Pole)	AC 240V / AC 277V	120	150	180	210	240
	AC 480V	100	125	150	175	200
	AC 600V	80	100	120	140	160
Rated Current w/resistance load (A)		30	35	40	50	50
Full Rated Current (A)		20	25	30	35	40
Mechanical / Electrical life ( 10 thousand )		50/25	50/25	50/25	50/25	50/25
Operation frequency ( time / hour )		360	360	360	360	360
Coil Control Voltage 50/60 Hz		24 / 110-120 / 200 / 220 / 208-240 / 277				

Note: locked rotor current is the rotor current when the motor/compressor rotor is locked/immobilized, i.e. “starting current” as it is typically named.

### ● Applicable scope

Applicable to the motor protective system in air-conditioning equipment, refrigerator or the control of the heater, motor, pump, fan, compressor in other industrial equipment.

### ● Operating environment

- Altitude below 2000m
- Ambient temperature: -40°C~65°C (dew is not allowed)
- Relative humidity: 45~85%RH

### ● Installation direction

The normal installation direction of SF series contactor is vertical, but is allowed to tilt 30° along the front and the rear directions; and is allowed to rotate 360° along the front direction for installation.

Charact-eristics

SP

Series

MS

Series

Other

Series

Coil

TH

Series

SD

Series

Selec-tion

Others

## Magnetic Control Relays



Type		SR-P40	SR-P50	SR-P80
Auxiliary Contact		4NO 3NO 1NC 2NO 2NC	5NO 4NO 1NC 3NO 2NC 2NO 3NC	8NO 7NO 1NC 6NO 2NC 5NO 3NC 4NO 4NC
Rated Capacity IEC 60947-4-1 AC15 (A)	220V	1.6	1.6	1.6
	380V	0.95	0.95	0.95
Rated impulse voltage (Ui) (V)		660	660	660
Operation current (Ith) (A)		16	16	16
Contact Class (UL)		A600, Q300	A600, Q300	A600, Q300
Electrical Life (10 thousand)		50 and up	50 and up	50 and up
Mechanical Life (10 thousand)		500	500	500
On/ Off Frequency (time per / hour)		500	500	500

### Other | SR Series | Anti-surge interference type

Type		SR-P40SA	SR-P50SA	SR-P80SA
Contact structure		4NO 3NO 1NC 2NO 2NC	5NO 4NO 1NC 3NO 2NC 2NO 3NC	8NO 7NO 1NC 6NO 2NC 5NO 3NC 4NO 4NC
Rated capacity (A)	AC 12 (IEC)	110V	6	6
		220V	5	5
		440V	3	3
		550V	3	3
	DC 12 (IEC)	24V	5	5
		48V	3	3
		110V	0.3	0.3
		220V	0.2	0.2
Continuous conducting current (Ith)(A)		16	16	16
contact class (UL)		A600,Q300	A600,Q300	A600,Q300
Electrical life (10 thousand times)		50	50	50
Mechanical Life (10 thousand times)		500	500	500

## Auxiliary Contact Block

### ◆ AP Series



Installation		2P FRONT MOUNTED TYPE			4P FRONT MOUNTED TYPE			SIDE MOUNTED TYPE	
Type		AP-20	AP-11	AP-02	AP-40	AP-31	AP-22	APS-11	APL-11
Contact		2NO	1NO 1NC	2NC	4NO	3NO 1NC	2NO 2NC	1NO 1NC	1NO 1NC
Applicable contactor		SR-P40, SR-P50 S-P11~ S-P80T SD-P11~ SD-P21			SR-P40, SR-P50 S-P11~ S-P80T SD-P11~ SD-P21			SR-P40, SR-P50 S-P11~ S-P60T SD-P11~ SD-P21	
Rated Capacity AC 15 (A)	220V	1.6							
	380V	0.95							
Operation current	(Ith) (A)	16							

## Auxiliary Contact Block

### ◆ MAP Series

Installation		2P FRONT MOUNTED TYPE			4P FRONT MOUNTED TYPE		
Type		MAP-20	MAP-11	MAP-02	MAP-40	MAP-31	MAP-22
Contact		2NO	1NO 1NC	2NC	4NO	3NO 1NC	2NO 2NC
Applicable contactor		S-P06, S-P09.					
Rated Capacity AC 15 (A)	220V	3.3					
	380V	1.9					
Operation current	(Ith) (A)	10					

## Timer



Type		PTR-30		PTR-180	
Contact		1NO 1NC		1NO 1NC	
Adjustable time (Sec)		0~30		0~180	
Applicable contactor		SR-P40, SR-P50, S-P11~ S-P60T, SD-P11~ SD-P21.			
Rated Capacity AC 15 (A)	220V	1.6			
	380V	0.95			
Operation current	(Ith) (A)	16			



## Varistors: Anti-surge interference

Type		BMSACW220V		BMSACW380V	
Applicable contactor		SR-P40, SR-P50, S-P11~ S-P60T.			

Charact-eristics

SP

Series

MS

Series

Other

Series

Coil

TH

Series



SD

Series

Selec-tion

Others

Push button | PB Series

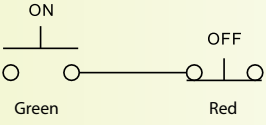
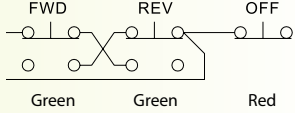
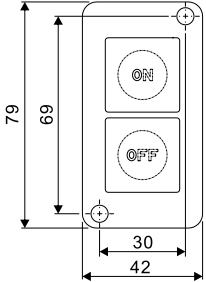
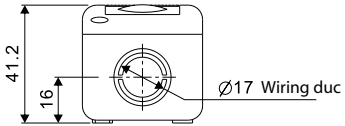
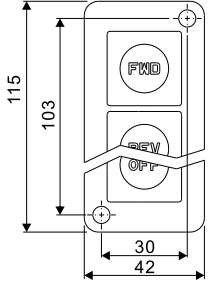
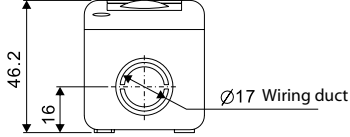
Type	PB2	PB3
		
Contact structure		
External dimensions (mm)	 	 
WET.	72.5g	110g

Separate Mounting Unit



Type	UATP12
TOR	TH-P12

## Coil Characteristics

Type		S-P06 S-P09	S-P11 S-P15	S-P12	S-P16 S-P21 S-P25 S-P30T	S-P35T S-P40T	S-P50T S-P60T S-P80T	S-P100T	S-P125T S-P150T	S-P200T S-P220T	S-P300T S-P400T	M-600C
Characteristics												
Coil Capacity (VA)	Impulse	25	55	55	55	72	250	319	370	440	700	4840
	Operation	5	11	11	11	12	28	36	42	50	50	242
Power Consumption (W)		1.6	2.5	2.5	2.5	3	7	11	10	12	7	80
Operation Vot. (Ue)	On	55~70%	55~68%	55~68%	59~70%	60~75%	63~75%	65~75%	75~80%	75~80%	65~80%	72~79%
	Off	35~50%	34~48%	34~48%	36~52%	40~57%	40~57%	40~55%	40~55%	40~60%	20~50%	59~66%
Close Time (ms)	Aux. OFF	5-12	5-12	4-11	6-14	6-13	6-13	18-28	9-20	10-19	22-37	42-71
	Aux. ON	6-15	10-18	10-18	10-18	12-20	12-20	22-32	15-24	17-25	25-40	49-78
	Contact ON	6-15	10-18	10-18	10-18	12-20	12-20	22-32	10-20	12-27	30-45	51-80
Open Time (ms)	Aux. OFF	6-15	12-20	9-18	9-19	10-17	10-17	50-100	9-18	10-20	40-60	61-97
	Aux. ON	5-12	8-15	4-13	6-14	5-12	5-12	48-98	7-15	7-18	31-51	58-94
	Contact ON	5-12	8-15	4-13	6-14	5-12	5-12	46-96	7-15	7-20	30-50	57-93

## Coil Specification Table

◆ S-P06~S-P25, S-P30T~P220T, SR-P40~P50, SC-P12~P60						
Description	AC12V	AC24V	AC48V	AC110V	AC120V	AC220V
Coil rated specifications marking	12V 50Hz 12V 60Hz	24V 50Hz 24V 60Hz	48~50V 50Hz 48~50V 60Hz	100V 50Hz 100~110V 60Hz	110~120V 50Hz 115~120V 60Hz	200~220V 50Hz 220V 60Hz
Description	AC240V	AC380V	AC440V	AC480V	AC550V	
Coil rated specifications marking	220~240V 50Hz 240~260V 60Hz	346~380V 50Hz 380V 60Hz	400V 50Hz 400~440V 60Hz	415~440V 50Hz 460~480V 60Hz	500V 50Hz 500~550V 60Hz	
◆ S-P300T~P400T						
Description	AC48V	AC220V	AC380V	AC550V		
Coil rated specifications marking	AC 48~50V 50/60Hz DC 48V	AC 100~240V 50/60Hz DC 100~220V	AC 265~450V 50/60Hz	AC 440~575V 50/60Hz		
◆ M-600C						
Description	AC110V	AC120V	AC220V	AC260V		
Coil rated specifications marking	100V 50Hz 100~110V 60Hz	110~120V 50Hz 115~120V 60Hz	208~220V 50Hz 220V 60Hz	240~260V 50Hz 260~280V 60Hz		
Description	AC380V	AC440V	AC480V	AC550V		
Coil rated specifications marking	346~380V 50Hz 380V 60Hz	380~415V 50Hz 400~440V 60Hz	415~440V 50Hz 460~480V 60Hz	500V 50Hz 500~550V 60Hz		

Charact-eristics

SP

Series

MS

Series

Other

Series

Coil

TH

Series

SD

Series

Selec-tion

Others

Thermal overload relay | TH Series

Type designation



TH-P20TA

TH	-	P	20	E	TA	PP
1	2	3	4	5	6	6

<b>1</b>	<b>Model</b>	
	TH	Thermal overload (overcurrent) relay
<b>2</b>	<b>Series</b>	
	P	P series
<b>3</b>	<b>Rated Capacity</b>	
		12、18、20、60、120、200、400、600
<b>4</b>	<b>Type</b>	
	Blank	Two-element or Phase failure protection type
	E	Three-element
<b>5</b>	<b>Contact/CT</b>	
	Blank	Contact without TA
	TA	with TA contact
		20 type = 28A~40A ( Other Ampere is left blank )
		60 type = 67A~80A ( Other Ampere is left blank )
		120 type = 105A~160A ( Other Ampere is left blank )
	CT	CT included (current transformer) ; only for 220、400、600 type
<b>6</b>	<b>TH Type</b>	
	Blank	Two-element (standard) or Three-element
	PP	Phase failure protection type

- Charact-eristics
- SP  
Series
- MS  
Series
- Other  
Series
- Coil
- TH**  
Series
- SD  
Series
- Selec-tion
- Others

# Thermal Overload Relay



Type		09		12		20			
Standard	Contactored Assembled Type	—		TH-P12(E)		TH-P20(E)		TH-P20(E)TA	
	#3 Independently Installed Type	—		TH-P12R(E)		—		—	
With phase failure protection	Contactored Assembled Type	TH-P09PP		TH-P12PP		TH-P20PP		TH-P20TAPP	
	#3 Independently Installed Type	—		TH-P12PPR		—		—	
Reset Mode		Manual / Automatic		Manual / Automatic		Manual / Automatic			
Magnetic Contactor		S-P06, S-P09.		S-P11, S-P12, S-P15.		S-P16, S-P21, S-P25, S-P30T, S-P35T, S-P40T.		S-P25, S-P30T, S-P35T, S-P40T.	
Thermal Overload Relay Range (A)	Rated (A)	Adjustable Range (A)	Rated (A)	Adjustable Range (A)	Rated (A)	Adjustable Range (A)	Rated (A)	Adjustable Range (A)	
	0.13	0.1~0.16	0.25	0.19~0.31	0.25	0.19~0.31	28	22~34	
	0.20	0.16~0.24	0.4	0.3~0.5	0.4	0.3~0.5	33	28~38	
	0.32	0.24~0.4	0.6	0.45~0.75	0.6	0.45~0.75	40	32~48	
	0.5	0.4~0.6	0.9	0.7~1.1	0.9	0.7~1.1			
	0.8	0.6~1	1.2	0.9~1.5	1.2	0.9~1.5			
	1.3	1~1.6	1.7	1.3~2.1	1.7	1.3~2.1			
	2.0	1.6~2.4	2.1	1.6~2.6	2.1	1.6~2.6			
	3.2	2.4~4	3.3	2.5~4.1	3.3	2.5~4.1			
	5	4~6	4.4	3.4~5.4	4.4	3.4~5.4			
	7.5	6~9	6.5	5~8	6.5	5~8			
			9	7~11	9	7~11			
			11	9~13	11	9~13			
			15	12~18	15	12~18			
				21	17~24				
Auxiliary Contact		—		—		1NO 1NC			
Weight		0.075		0.11/ 0.12		0.18/ 0.19		0.20/ 0.21	
Dimensions (mm) (L×W×H)		64.8×45.5×50		TH-P12(PP): 55.5×45.5×78 TH-P12(PP)R: 71×47×86.2		TH-P20(PP): 46.1×64.5×80		TH-P20TA(PP): 56.2×64.5×80	

Installation Dimensions (mm)

—

TH-P12(PP):  
TH-P12(PP)R:

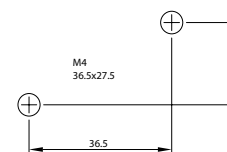
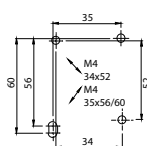

- Note. 1. The purpose of using TOR is protecting load tripping. For protecting circuit, please choose circuit breaker.  
2. When adjusting the rated current; please refer to the TOR range table above. Do not exceed its range.  
3. (E): 3 Elements

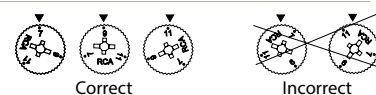



Type		60				120				
Standard	Contactor Assembled Type	TH-P60(E)		TH-P60(E)TA		TH-P120(E)		TH-P120(E)TA		
	Independently Installed Type	-		-		-		-		
With phase failure protection	Contactor Assembled Type	TH-P60PP		TH-P60TAPP		TH-P120PP		TH-P120TAPP		
	Independently Installed Type	-		-		-		-		
Reset Mode		Manual / Automatic				Manual / Automatic				
Magnetic Contactor		S-P50T, S-P60T, S-P80T.		S-P60T, S-P80T.		S-P100T, S-P125T, S-P150T.				
Thermal Overload Relay Range (A)		Rated (A)	Adjustable Range (A)	Rated (A)	Adjustable Range (A)	Rated (A)	Adjustable Range (A)	Rated (A)	Adjustable Range (A)	
		11	9~13	67	54~80	40	32~48	105	80~130	
		15	12~18	80	60~100	54	43~65	130	100~160	
		21	17~24			67	54~80	160	120~200	
		28	22~34			80	60~100			
		33	28~38							
		40	32~48							
		54	43~65							
Auxiliary Contact		1NO 1NC				1NO 1NC				
Weight		0.28 / 0.30		0.34 / 0.36		0.55		0.76		
Dimensions (mm) (L×W×H)		TH-P60(PP): 50.5×98×78		TH-P60TA(PP): 65.5×64.5×80		TH-P120(PP): 54×133×105		TH-P120TA(PP): 85.5×133×105		

Installation Dimensions (mm)

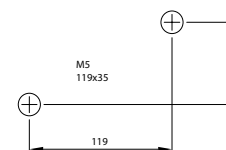
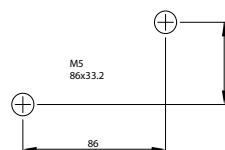

Note. 1. The purpose of using TOR is protecting load tripping. For protecting circuit, please choose circuit breaker.  
 2. When adjusting the rated current; please refer to the TOR range table above. Do not exceed its range.  
 3. (E): 3 Elements

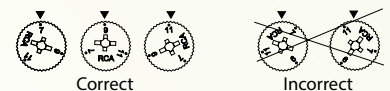



Charact-eristics

SP

Series

MS

Series

Other

Series

Coil

TH

Series

SD

Series

Selec-tion

Others

TH-P12(E) tripping characteristic curve

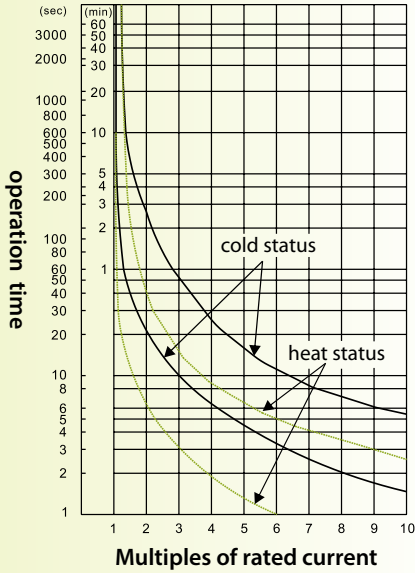

TH-P18(E) – below 6.5A tripping characteristic curve

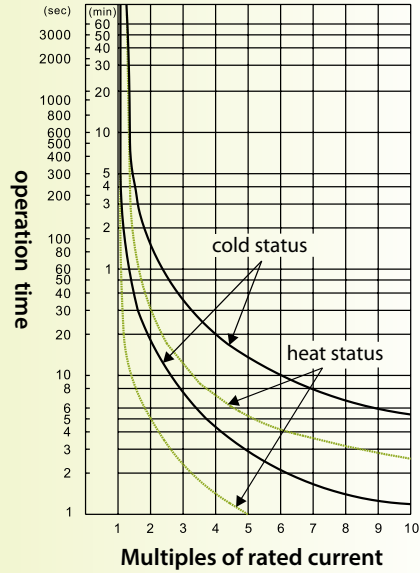

TH-P18(E) – above 9A tripping characteristic curve

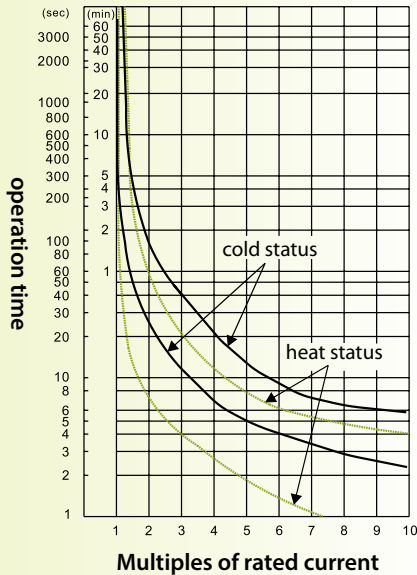

TH-P20(E)-below 6.5A tripping characteristic curve

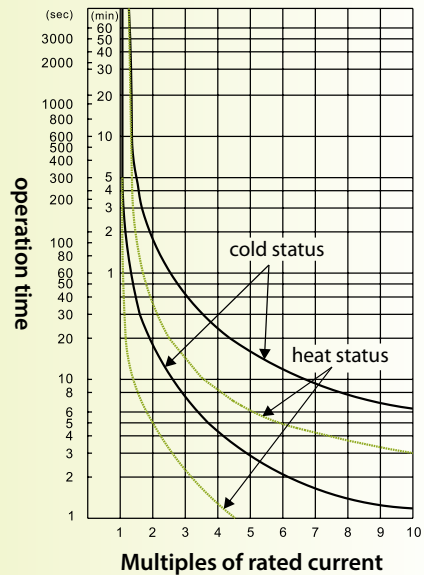

TH-P20(E)(TA) above 9A tripping characteristic curve

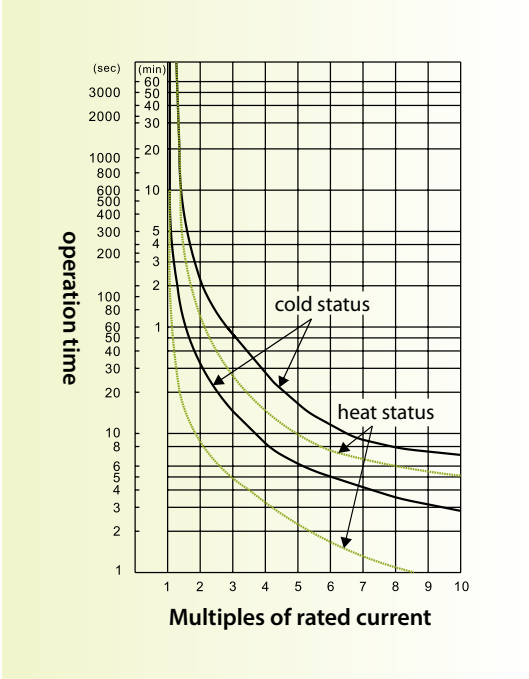

TH-P60(E)(TA) tripping characteristic curve

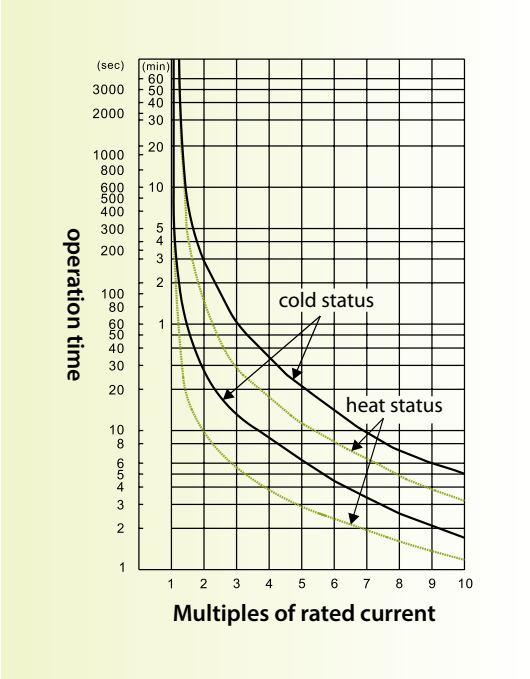

TH-P120(E)(TA) tripping characteristic curve

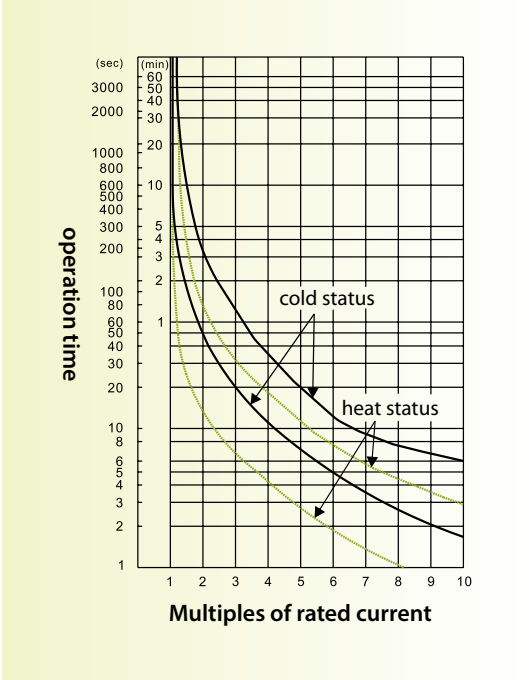

TH-P220(E)CT, P400(E)CT, TH-P220T(E) P400T(E) 130A tripping characteristic curve

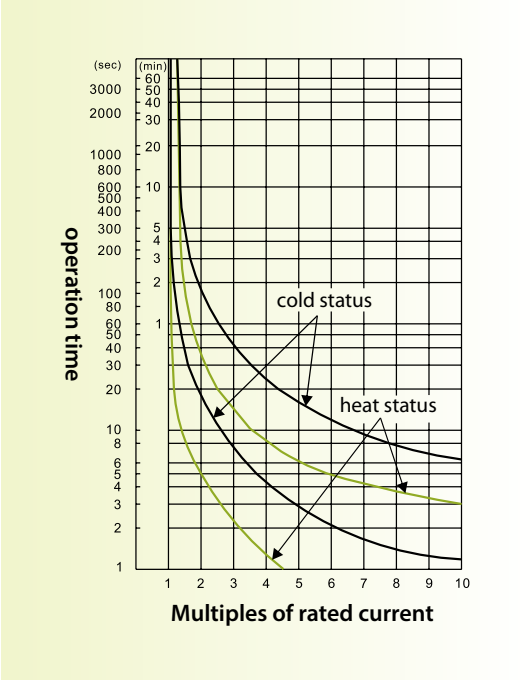

Charact-eristics

SP

Series

MS

Series

Other

Series

Coil

TH

Series

SD

Series

Selec-tion

Others

Thermal overload (overcurrent) relay | TH Series

Tripping Characteristic

TH-P220(E)CT、TH-P400(E)CT、TH-P220T(E)  
TH-P400T(E) 160A tripping characteristic curve

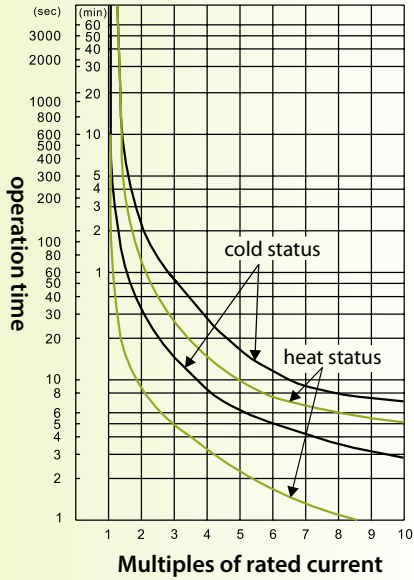

TH-P600(E)CT tripping characteristic curve

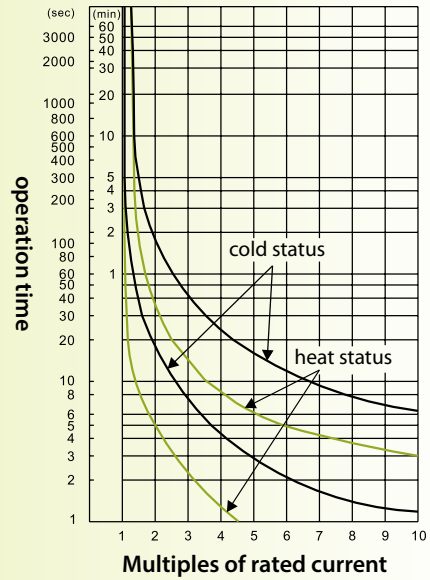

TH-P12PP tripping characteristic curve

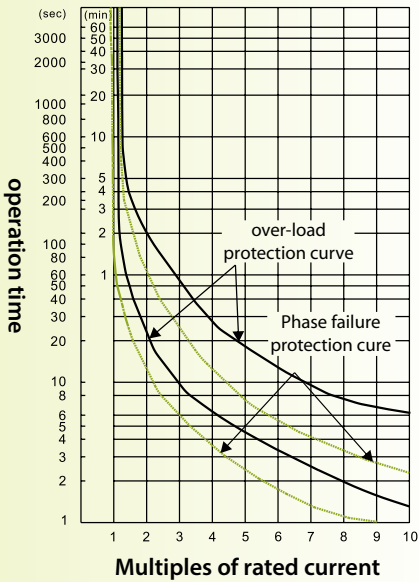

TH-P20(TA)PP tripping characteristic curve

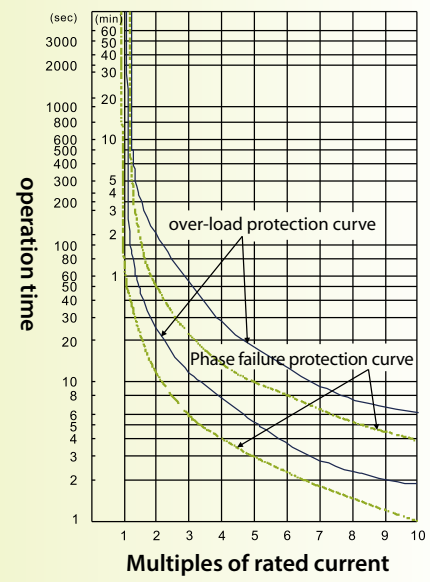

- Characteristics
- SP Series
- MS Series
- Other Series
- Coil
- TH Series
- SD Series
- Selection
- Others

TH-P60(TA)PP tripping characteristic curve

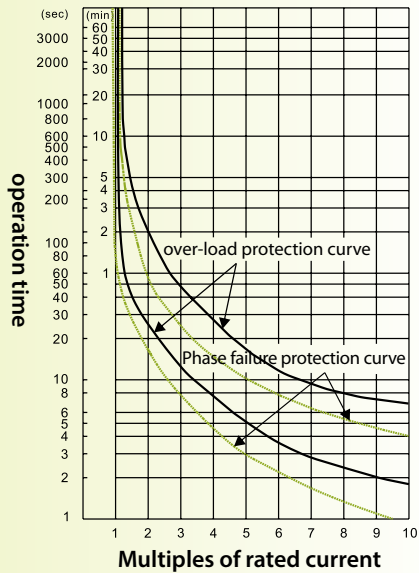

TH-P120(TA)PP tripping characteristic curve

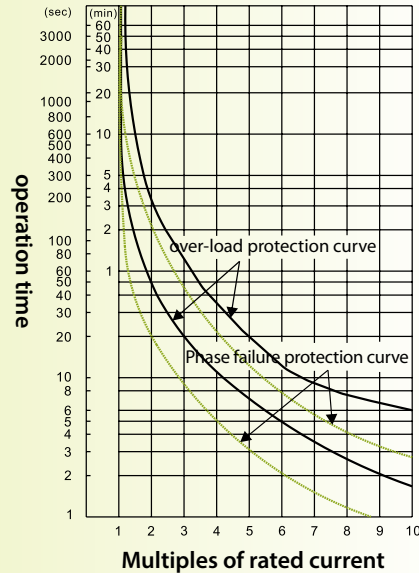

TH-P220CTPP、P400CTPP、P600CTPP、TH-P220TPP、P400TPP tripping characteristic curve

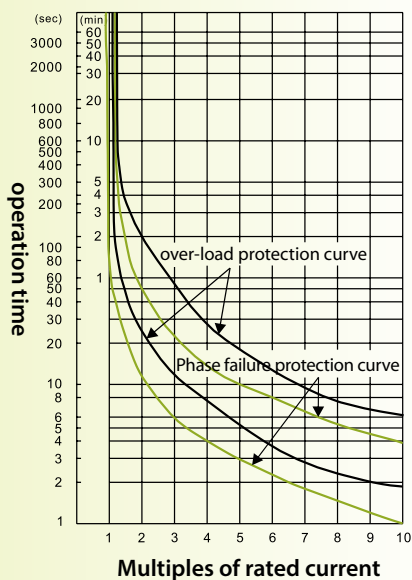

Charact-eristics

SP

Series

MS

Series

Other

Series

Coil

TH

Series

SD

Series

Selec-tion

Others

Reduced voltage starting switch | SD Series (Y-D Starter)

Type designation

SD	-	O	P35	T	380V/	220V	28A	E
①		②	③	④	⑤	⑥	⑦	⑧

Characteristics

SP

Series

MS

Series

Other

Series

Coil

TH

Series

SD

Series

Selection

Others



SDO-P60



SDE-P21

①	<b>Model</b>	
	SD	Star-delta Starter
②	<b>Type</b>	
	O	without enclosure
	E	with enclosure , Push button 、 Indicator lamp
	A	with enclosure , Push button 、 Indicator lamp 、 Ammeter
③	<b>Rated capacity</b>	
		21 、 35 、 50 、 60 、 80 、 100 、 125 、 150 、 200 、 220
④	<b>Contact / CT</b>	
	Blank	CT not included
	T	CT included
⑤	<b>Main circuit voltage</b>	
		EX : 110V 、 220V 、 380V 、 440V... When main circuit voltage and control circuit voltage are the same, it will be blank.)
⑥	<b>Control circuit voltage</b>	
		EX : 110V 、 220V 、 380V 、 440V...
⑦	<b>TH heater rated capacity</b>	
		EX : 40A 、 54A...350A...
⑧	<b>TH Type</b>	
	Blank	Standard (Two-element)
	E	Three-element
	PP	Phase failure protection type

## • Structure, principle

When starting by  $\lambda - \Delta$  starting method, starting current and torque of motor will be reduced to 1/3 of those of direct starting; the purpose is to suppress starting current, but somehow it also suppresses torque at the same.

Comparison table between direct starting and  $\lambda - \Delta$  starting (the values in the table are all shown in %)

Starting method	When starting			In operation	
	Linear current (starting current)	Torque	Linear voltage (power voltage)	Linear current (loading current)	Phase current
Direct starting	600	150	100	100	$100 \times 1/\sqrt{3}=58$
$\lambda - \Delta$ starting	$600 \times 1/3=200$	$150 \times 1/3=50$	100	100	$100 \times 1/\sqrt{3}=58$

## • Operating circumstance

### (1) Unloaded starting circumstance.

- e.g.:
- (1-1) Starting the driving shaft of machine tool.
  - (1-2) Typical starting of woodworking machinery.
  - (1-3) Starting of grinding, drilling machines etc.
  - (1-4) Motor with clutch.

### (2) Light loading circumstance.

- e.g.:
- (2-1) Small-size belt conveyer.
  - (2-2) Light loading air compressor or water pump.
  - (2-3) Stamping press etc.

### (3) Equipment that needs to limit starting current.

### (4) Equipment that needs to reduce starting impact.

## • Notes

- (1) When speed of the motor exceeds 80% of rated value, it is the optimal time to perform  $\lambda - \Delta$  switching.
- (2) Starting time of  $\lambda$  can be defined according to motor capacity  $\sqrt{(kW)}$ . Use the equation  $t = 4 + 2$  to derive the time required (second)
- (3) When starting by  $\lambda - \Delta$ , ensure the power supply capacity is sufficient to prevent voltage drop in power supply during transition from  $\lambda$  starting to operation, which could cause the contactor to break or burn out.

Remarks:

1. Three-phase induction motor can be started by the following methods:
  - (1) Full voltage direct starting.
  - (2) Reduced voltage starting.
    - (2-1)  $\lambda - \Delta$  starting.
    - (2-2) Reactor starting.
    - (2-3) Self-coupled transformer starting.
    - (2-4) Primary resistor starting.
2. If the motor is not limited by its starting method, direct starting can be applied for all large or small-size models. If all motors are started by direct starting, the stability of system power supply will definitely be impacted. When starting, all the appliances connected to the same loop circuitry will be influenced by voltage drop. Lamps will flash and the motor will trip, due to overload of increased current resulting from low voltage. Therefore, national standards or power company internal regulations always define the circumstances that require reduced voltage starting.

Charact-eristics

SP

Series

MS

Series

Other

Series

Coil

TH

Series

SD

Series

Selec-tion

Others

Reduced voltage starting switch | SD Series (Y-D Starter)

Model		21		35		50		60		80		100		125		150		220	
Type	Open	SDO-P21		SDO-P35		SDO-P50		SDO-P60		SDO-P80		SDO-P100		SDO-P125		SDO-P150		SDO-P220	
		SDO-P21T		SDO-P35T		SDO-P50T		SDO-P60T		SDO-P80T		SDO-P100T		SDO-P125T		SDO-P150T		SDO-P220T	
	Enclosure	SDE-P21		SDE-P35		SDE-P50		SDE-P60		SDE-P80		SDE-P100		SDE-P125		SDE-P150		SDE-P220	
		SDA-P21		SDA-P35		SDA-P50		SDA-P60		SDA-P80		SDA-P100		SDA-P125		SDA-P150		SDA-P220	
Rated capacity	Rated voltage	kW	HP	kW	HP	kW	HP	kW	HP	kW	HP	kW	HP	kW	HP	kW	HP	kW	HP
	200~220V	11	15	19	25	22	30	30	40	37	50	45	60	55	75	75	100	110	150
	380~440V	19	25	30	40	45	60	55	75	75	100	90	125	110	150	132	180	200	260
AC contactor	MCM	S-P21		S-P35T		S-P50T		S-P60T		S-P80T		S-P100T		S-P125T		S-P150T		S-P220T	
	MCD	S-P21		S-P35T		S-P50T		S-P60T		S-P80T		S-P100T		S-P125T		S-P150T		S-P220T	
	MCS	S-P11		S-P16		S-P21		S-P21		S-P35C		S-P35T		S-P50T		S-P50T		S-P60T	
TOR	TH-P20		TH-P60		TH-P60		TH-P120		TH-P120		TH-P120		TH-P220T		TH-P220T		TH-P400T		
	TH-P20TA		TH-P60TA		TH-P60TA		TH-P120TA		TH-P120TA		TH-P120TA		TH-P220T		TH-P400T		TH-P400T		
Wire (mm <sup>2</sup> )	Line	2.5~16		2.5~25		2.5~35		2.5~50		10~70		10~95		35~150		35~150		35~240	
	Load	2.5~10		2.5~16		2.5~25		2.5~35		4~50		4~70		10~95		10~90		16~150	
	Control circuit	1~2.5		1~2.5		1~2.5		1~2.5		1~2.5		1~2.5		1~2.5		1~2.5		1~2.5	

- Note: 1. SDE-P21~P220 is with enclosure, push button, indicator light and door lock.  
 2. SDA-P21~P220 is with enclosure, push button, indicator light, door lock, and current meter.  
 3. SDO-P21~P220 is attached with CT as current meter.



SDA-P50



SDA-P50

Wiring

Connection with Breaker

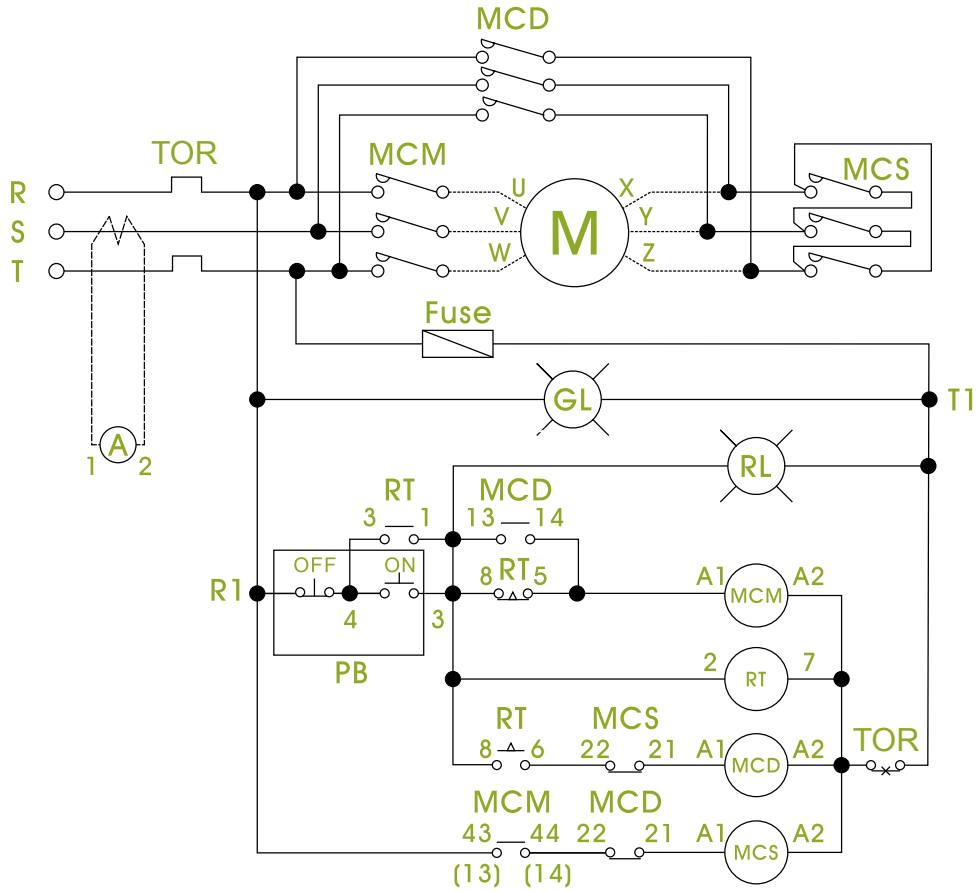

Symbol descriptions

MC	Magnetic contactor	GL	Indicator light (green)	A	Ammeter
TOR	Thermal overload (overcurrent) relay	RL	Indicator light (red)	Fuse	Fuse
RT	Time limited relay	CT	Current transformer	PB	Push button

1. The numbers in the parentheses are applicable to Model P80~P220 type.
2. Setting time for RT (Timer):  $t = 4 + 2\sqrt{kW}$  ( $\pm 1$  second)

Selection Table ◆ λ - Δ Starter

Heater selection table (A)	Motor output kW (HP)				TH selection of λ - Δ Starter																	
	A		B		21		35		50		60		80		100		125		150		220	
	200~220V		380~440V		A	B	A	B	A	B	A	B	A	B	A	B	A	B	A	B	A	B
6.5	1.5	(2)	3	(4)																		
9	1.9	(2 1/2)	3.7	(5)																		
9	2.2	(3)	4.5	(6)																		
11	3	(4)	5.5	(7 1/2)	TH-P20	TH-P20																
15	3.7	(5)	7.5	(10)																		
15	4.5	(6)	10	(13)																		
21	5.5	(7 1/2)	11	(15)																		
28	6.5	(8)	14	(19)																		
28	7.5	(10)	15	(20)	TH-P20TA	TH-P20TA																
33	9	(12 1/2)	19	(25)																		
40	11	(15)	22	(30)																		
40	14	(19)	26	(35)																		
54	15	(20)	30	(40)																		
67	19	(25)	37	(50)																		
80	22	(30)	45	(60)																		
80	25	(34)	50	(67)																		
105	30	(40)	55	(75)																		
130	37	(50)	75	(100)																		
160	45	(60)	90	(125)																		
200	55	(75)	110	(150)																		
200	65	(85)	132	(200)																		
260	75	(100)	150	(200)																		
350	110	(150)	200	(260)																		

- Characteristics
- SP Series
- MS Series
- Other Series
- Coil
- TH Series
- SD Series
- Selection
- Others



**Selection Table** ◆ **Direct On-Line Starter**

Motor rated capacity kW (HP)		3 φ 380V~440V		Selection of the contactor																							
		Heating element rating (A)																									
0.025	(1/30)	0.13A	0.1~0.16A	S-P06	S-P09																						
0.04	(1/19)	0.2A	0.16~0.24A																								
0.09	(1/8)	0.32A	0.24~0.4A																								
0.18	(1/4)	0.5A	0.4~0.6A																								
0.25	(1/3)	0.8A	0.6~1.0A																								
0.37	(1/2)	1.3A	1.0~1.6A																								
0.55	(3/4)	2.0A	1.6~2.4A																								
0.75	(1)																										
1.1	(1 1/2)	3.2A	2.4~4.0A																								
1.5	(2)	5A	4.0~6.0A																								
2.2	(3)																										
3	(4)	7.5A	6.0~9.0A																								
0.05	(1/15)	0.25A	0.19~0.31A	S-P11, S-P12	S-P15, S-P16	S-P21	S-P25	S-P30T	S-P35T	S-P40T																	
0.1	(1/8)	0.4A	0.3~0.5A																								
0.2	(1/4)	0.6A	0.45~0.75A																								
0.3	(2/5)	0.9A	0.7~1.1A																								
0.4	(1/2)	1.2A	0.9~1.5A																								
0.75	(1)	1.7A	1.3~2.1A																								
1.1	(1 1/2)	2.1A	1.6~2.6A																								
1.5	(2)	3.3A	2.5~4.1A																								
2.2	(3)	4.4A	3.4~5.4A																								
3	(4)	6.5A	5~8A																								
3.7	(5)	9A	7~11A																								
4	(5 1/2)																										
4.5	(6)	11A	9~13A																								
5.5	(7 1/2)																										
7.5	(10)	15A	12~18A																								
11	(15)	21A	17~24A																								
12	(16)																										
15	(20)	28A	22~34A																								
19	(25)	33A	28~38A																								
22	(30)	40A	32~48A																								
25	(35)																										
30	(40)	54A	43~65A																								
37	(50)	67A	54~80A																								
45	(60)																										
50	(70)	80A	60~100A																								
60	(80)	105A	80~130A																								
75	(100)	130A	100~160A																								
90	(125)	160A	120~200A																								
110	(150)	200A	150~250A																								
132	(180)																										
150	(200)	260A	200~320A																								
160	(220)	350A	260~440A																								
220	(330)																										
250	(350)	500A	400~600A																								
315	(420)																										

- Characteristics
- SP Series
- MS Series
- Other Series
- Coil
- TH Series
- SD Series
- Selection
- Others

# Selection Table ◆ Direct On-Line Starter

Motor rated capacity kW (HP)		Heating element rating (A)		3 φ 500V~550V																			
				Selection of the contactor																			
0.06	(1/12)	0.13A	0.1~0.16A	S-P06	S-P09																		
0.09	(1/8)	0.2A	0.16~0.24A																				
0.12	(1/6)	0.32A	0.24~0.4A																				
0.18	(1/4)	0.5A	0.4~0.6A																				
0.37	(1/2)	0.8A	0.6~1.0A																				
0.55	(3/4)	1.3A	1.0~1.6A																				
0.75	(1)	2.0A	1.6~2.4A																				
1.1	(1 1/2)	3.2A	2.4~4.0A																				
1.5	(2)	5A	4.0~6.0A																				
2.2	(3)	7.5A	6.0~9.0A																				
3	(4)			S-P11, S-P12	S-P15, S-P16	S-P21	S-P25	S-P30T	S-P35T	S-P40T													
4	(5 1/2)	0.12	0.19~0.31A																				
0.18	(1/4)	0.4A	0.3~0.5A																				
0.25	(1/3)	0.6A	0.45~0.75A																				
0.37	(1/2)	0.9A	0.7~1.1A																				
0.55	(3/4)	1.2A	0.9~1.5A																				
0.75	(1)	1.7A	1.3~2.1A																				
1.1	(1 1/2)	2.1A	1.6~2.6A																				
1.5	(2)	3.3A	2.5~4.1A																				
2.2	(3)	4.4A	3.4~5.4A																				
4	(5 1/2)	6.5A	5~8A	S-P50T	S-P60T	S-P80T																	
4.5	(6)	9A	7~11A																				
5.5	(7 1/2)	11A	9~13A																				
7.5	(10)	15A	12~18A																				
11	(15)	21A	17~24A																				
12	(16)	28A	22~34A																				
15	(20)	33A	28~38A																				
19	(25)	40A	32~48A																				
22	(30)	54A	43~65A																				
30	(40)	67A	54~80A																				
37	(50)	80A	60~100A																				
45	(60)	105A	80~130A																				
50	(70)	130A	100~160A																				
60	(80)	160A	120~200A																				
75	(100)	200A	150~250A																				
90	(125)	260A	200~320A																				
110	(150)	350A	260~440A																				
132	(180)	500A	400~600A																				
150	(200)			M-600C																			
160	(220)																						
220	(330)																						
315	(420)																						

## Installation notes

### • Operating environment

- Altitude below 2000m
- Ambient temperature: -5°C~40°C (dew is not allowed)
- Relative humidity: 45~85%RH
- Withstand vibration 10Hz~55Hz 2G
- Withstand impact 5G
- Storage temperature: -30°C~65°C (dew is not allowed)
- Please do not install in a place that contains dust, moisture, salt, oil stains, or corrosive or flammable gases.
- After switch installed, please add temporary protection to avoid harmful substances like dust or moisture etc coming into contact with it, if the switch is not to be used for a long period of time.
- Coil operating voltage should be applied within 85~110% of rated voltage. If higher than 110%, the coil life will be reduced, or the coil could burn out if lower than 85%.

### • Installation direction

The regular installation direction of the contactor is vertical, but is allowed 20° tilt along all directions. Refer to the figure below.

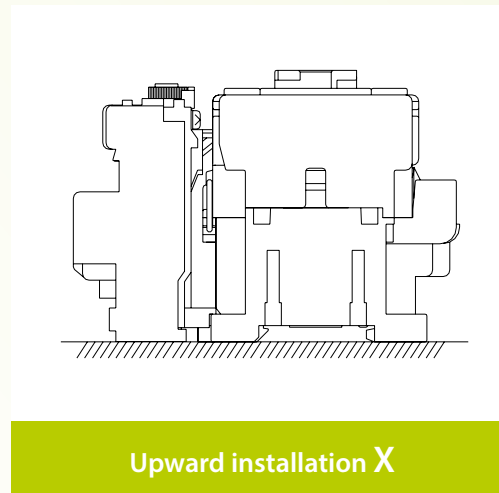
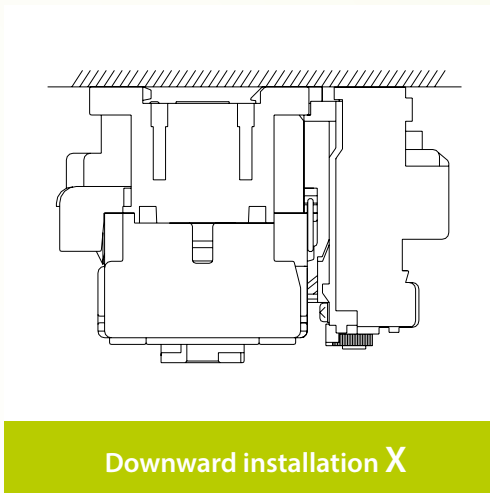
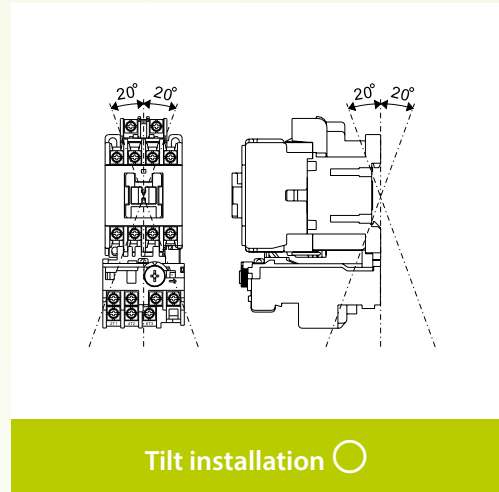
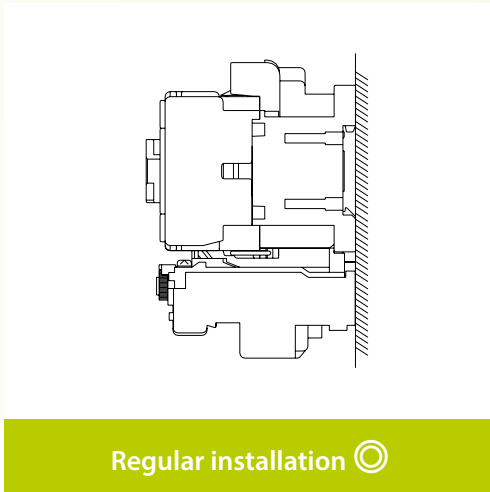

Note. If installation dimensional drawing is required, please contact regional distributor or e-mail : [b.export@seec.com.tw](mailto:b.export@seec.com.tw)



CIRCUIT BREAKER ( MCCB / ELCB / EMCCB / MCB )

## Breaker & Switchgear System



AIR CIRCUIT BREAKER

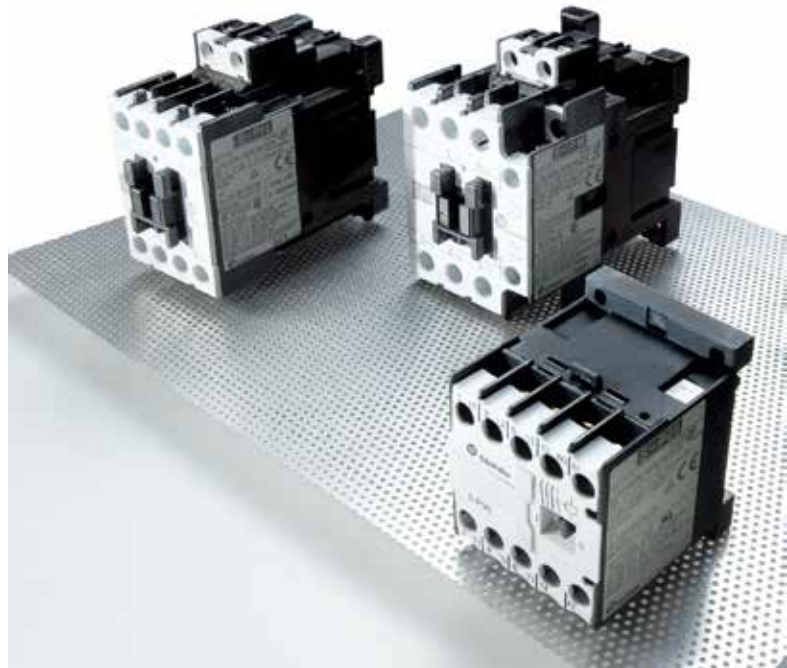

MOTOR CONTROL ( CONTACTOR / MS / MMS )



AUTOMATIC TRANSFER SWITCHES



SURGE PROTECTIVE DEVICE



SMART METER



INVERTER



LOW VOLTAGE POWER CAPACITORS

# SHIHLIN ELECTRIC & ENGINEERING

MOTOR CONTROL (CONTACTOR/ MS/ MMS), CIRCUIT BREAKER (MCCB/ ELCB/ EMCCB/ MCB), AIR CIRCUIT BREAKER, AUTOMATIC TRANSFER SWITCHES (Panel Board Type/ Residential Unit Use), SURGE PROTECTIVE DEVICE, LOW VOLTAGE POWER CAPACITORS, SMART METER, INVERTER



## **Breaker & switchgears overseas sales dept.**

3F, No.9, Sec. 1, Chang-an E. Rd., Zhongshan Dist., Taipei City 10441, Taiwan  
T. +886-2-2541-9822 F. +886-2-2581-2665  
e-mail. b.export@seec.com.tw  
<http://circuit-breaker.seec.com.tw>

## **Headquarters**

16F, No.88, Sec. 6, Zhongshan N. Rd., Shilin Dist., Taipei City 11155, Taiwan  
T. +886-2-2834-2662 F. +886-2-2836-6187  
<http://www.seec.com.tw>

Distributor

1305.ms-ob-2